

Specifications

S800 Unique Features

- The lifter is configurable as both a spider- type and line-type vacuum lifter
- Several extensions kits available, like:
 - o Adjustable frame usable for framed windows.
 - o Extended frame usable as 3.7-meter line-type vacuum lifter.
 - o Custom extensions kits are possible on request.
- The lifter weighs only 82 kg in full version, making it one of the lightest 800 kg vacuum lifter currently on the market.



The Grip S800 vacuum lifter is a multifunctional lifter, characterized by a high level of quality and detail and a competitive price.

We design all our products in house, in close cooperation with the end users. This leads to products which differentiate on just the right details and which are easy to use, every single day.

Specifications S800

Lifting Capacity Dual Circuit	200 / 400 / 600 / 800 kg
Machine Weight	55 / 64 / 73 / 82 kg
Rotational Range	360° with four locking positions
Tilting Range	90° with six locking positions
Machine Height / Thickness	190 mm
Battery	12VDC, 10Ah

Options

- Radio Remote Control
- Removable supports
- Transport-Trolley

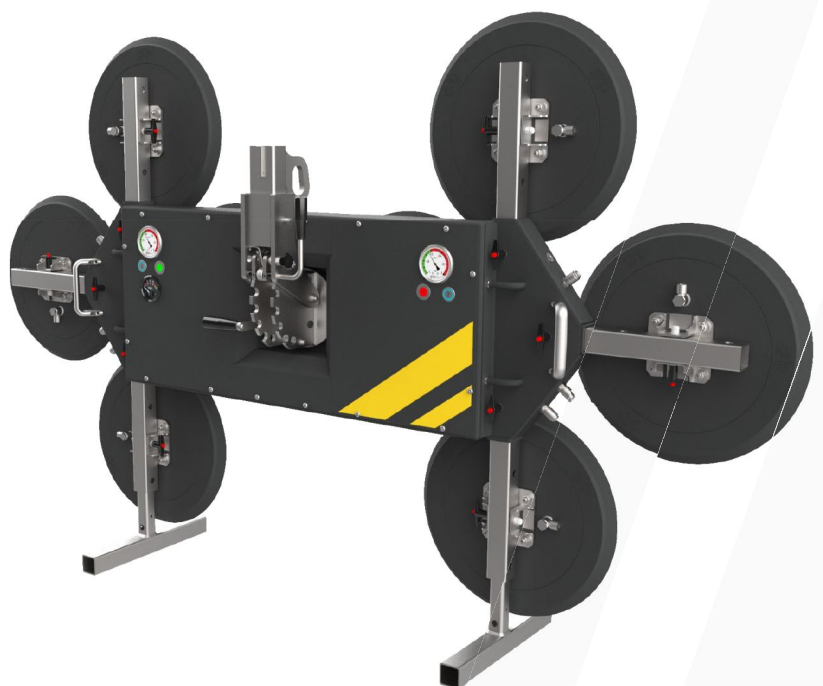

Grip Lifting Unique Features

- Extra short lifting arm resulting in a small minimal lifting height, useful for installation in narrow spaces.
- Six different tilting lock positions, making it easy to maneuver glass through narrow spaces and window frames.
- Dual vacuum system in accordance with the EN 13155 delivers maximum safety and ease of use, making additional safety straps obsolete.
- The total machine height is less than 200 mm, making it easy to work between the façade and scaffolding.

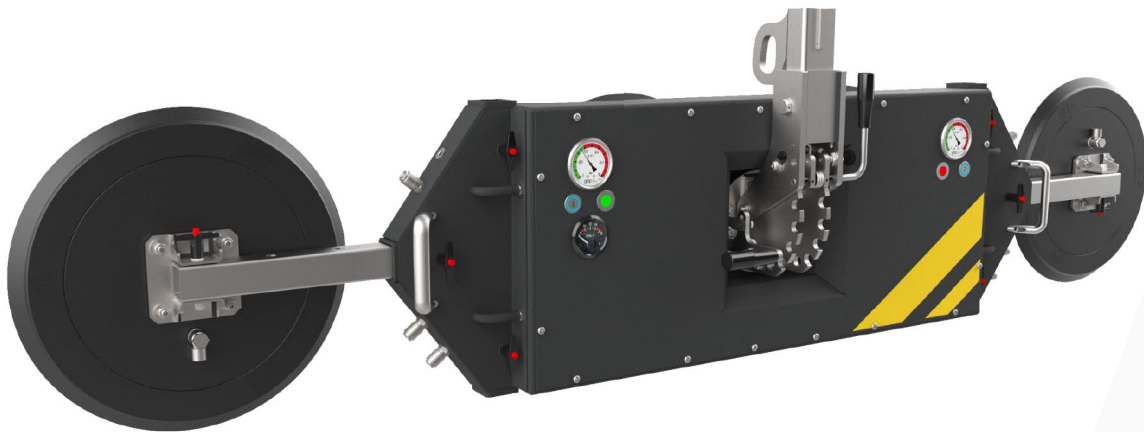

82kg – SWL 800 kg – Spider-type

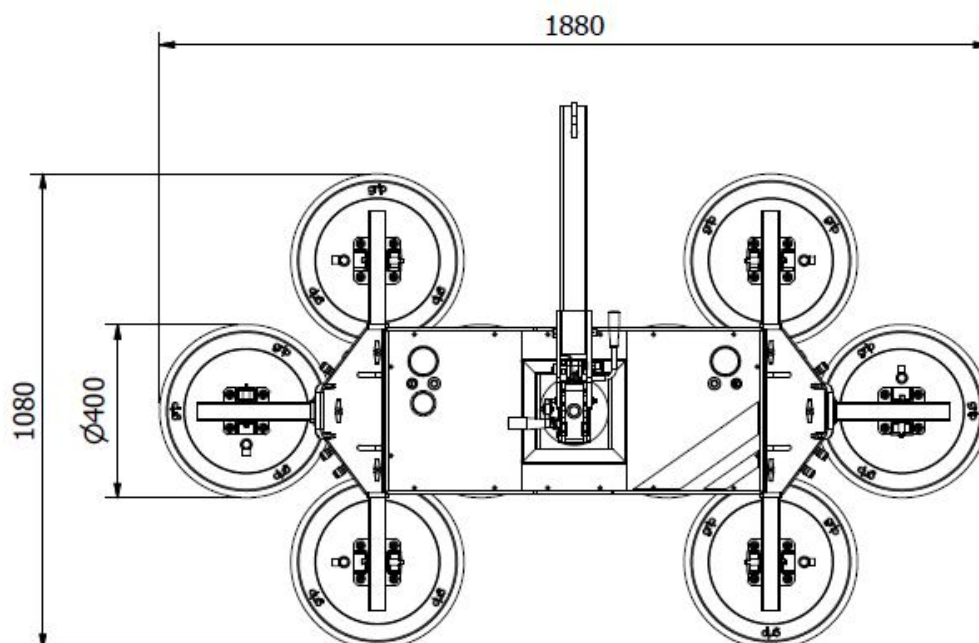
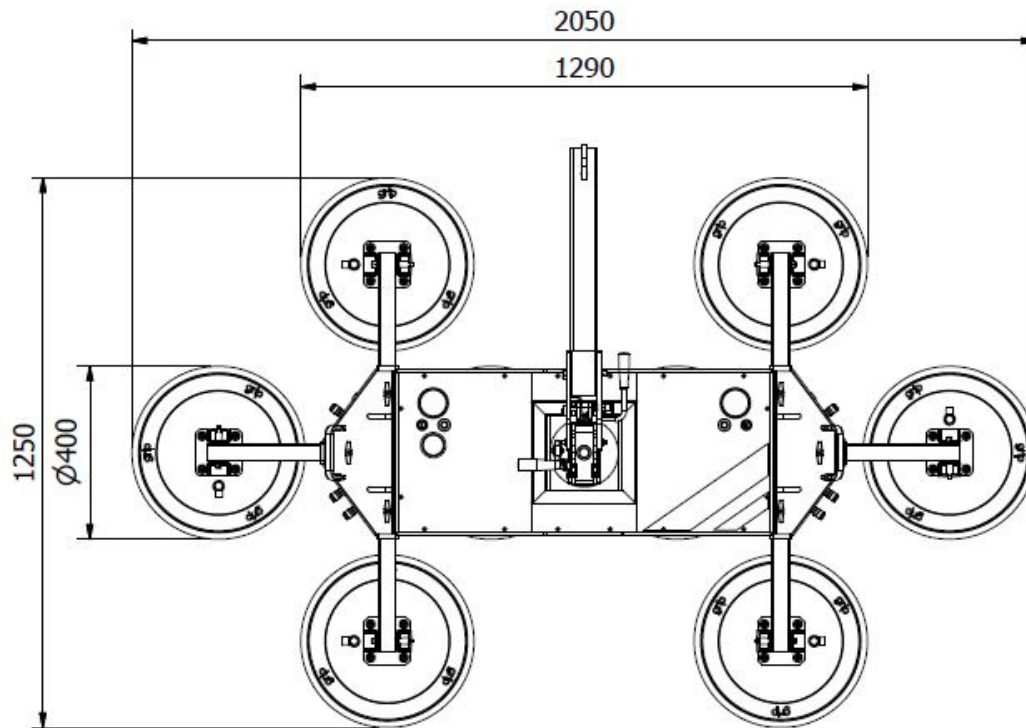

64kg – SWL 400 kg – Line-type

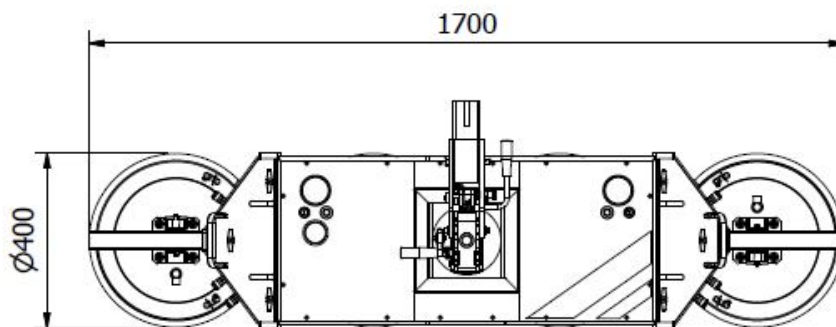
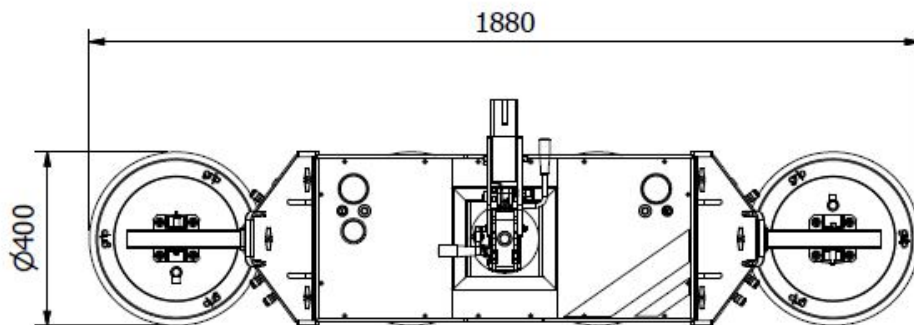
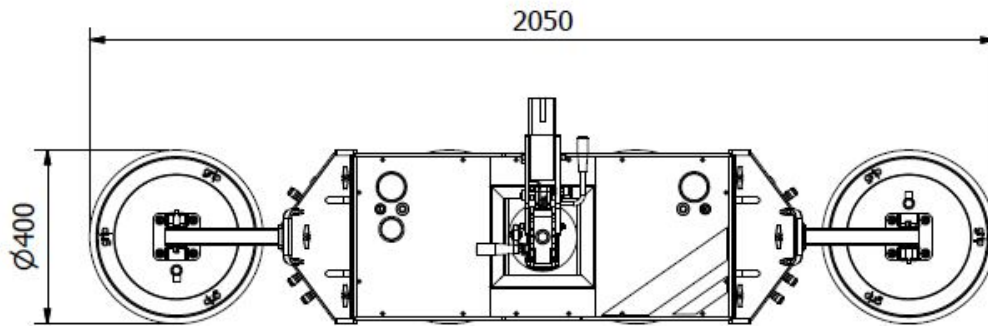

200 kg – Base-unit

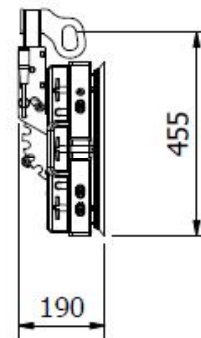
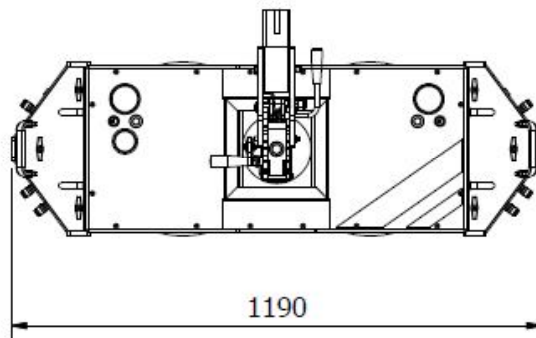

Lifting arm dimensions

